

**LIVE THE LAB LIFE**

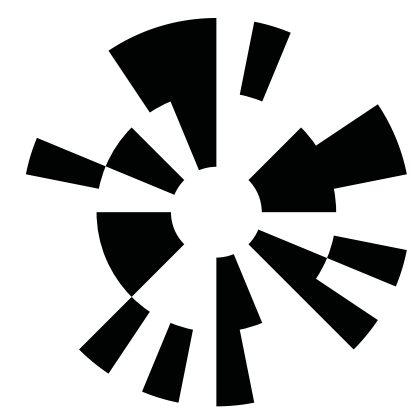

ARC  
West London

Refinery

# REFINERY

A new 150,000 sq ft lab enabled building, part of a science campus on the banks of the Thames. Accommodation ranging from fully fitted & managed labs from approx. 700 sq ft to single/multiple floors.

Live your best Lab Life at Refinery and plug into a new kind of life science workspace.

Come and work in ARC West London's new Refinery building. 150,000 sq ft of world-class, flexible, lab-enabled building designed to inspire your passion for innovation.

- Landscaped gardens and river setting
- 10 minutes walk from Hammersmith Tube
- Centre of West London Life Science cluster (Imperial College White City, Charing Cross & Hammersmith Hospitals)
- Serviced laboratory space with shared facilities from 700 sq ft
- Larger turnkey CL2 laboratory space available from 5,000 sq ft up to whole floors
- Established laboratory protocols
- Optionality around levels of finish from shell & core to fully fitted labs
- Ability to scale
- New F&B provisions plus top floor club room
- New open plan reception with business lounge
- ARC West London app



**JUST ADD H<sub>2</sub>O**



**A SCIENCE CAMPUS WHERE  
IDEAS CAN ALWAYS FLOW FREELY**

# INDUSTRIAL HERITAGE

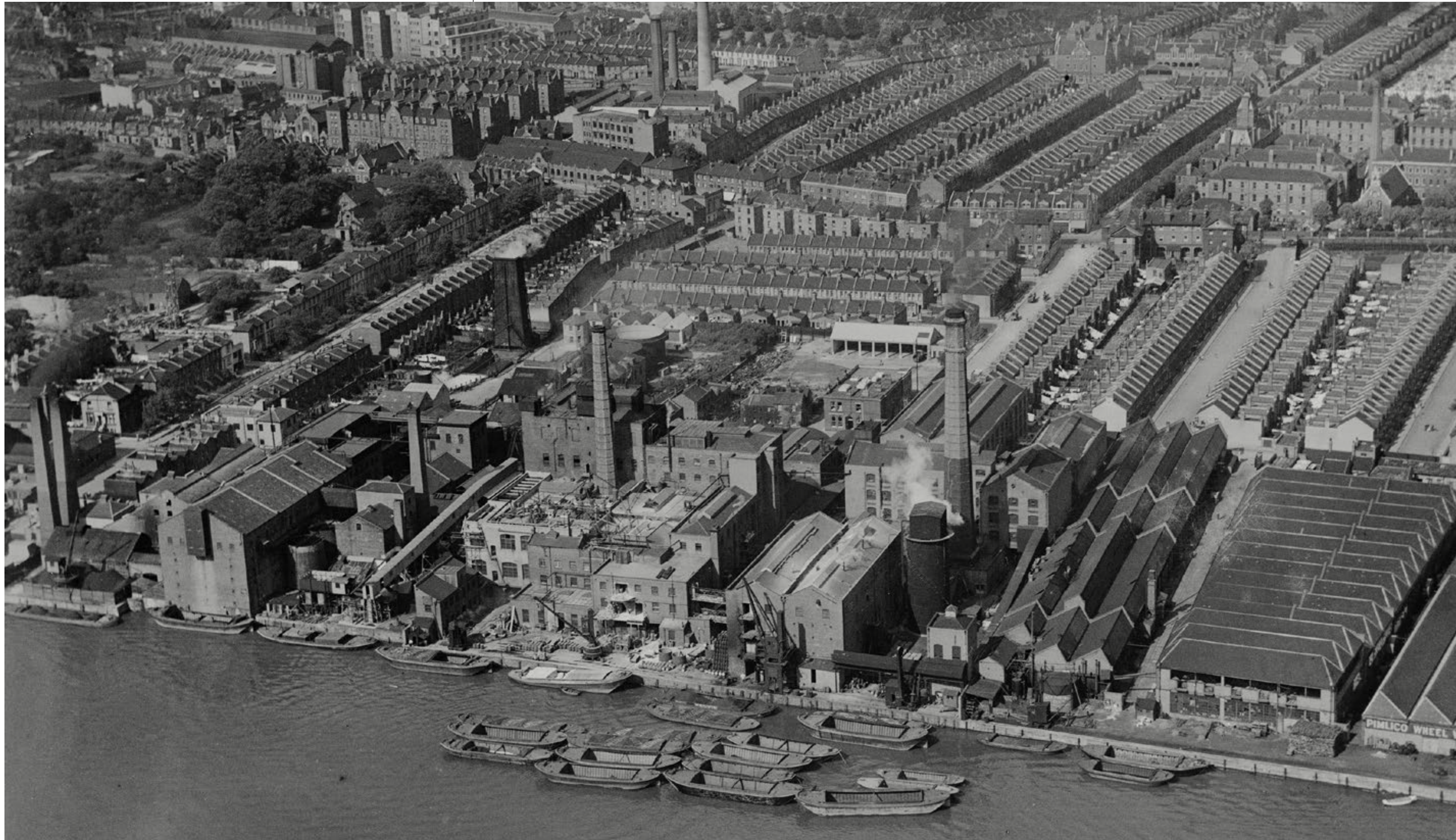

For more than a century, this stretch of the Thames was home to the Manbre and Garton Saccharine works. Today the visionary redevelopment of Refinery has rekindled the area's pioneering spirit, refining it into a workplace fit for 21st Century business.

# VISION

Refinery redefines where we work and play today with its 150,000 sq ft of state-of-the-art space in a campus environment. A creative social hub by the riverside with landscaped gardens creating engaging communal spaces. Inside, are light and modern open plan spaces, with stunning views offering a completely new perspective on work.

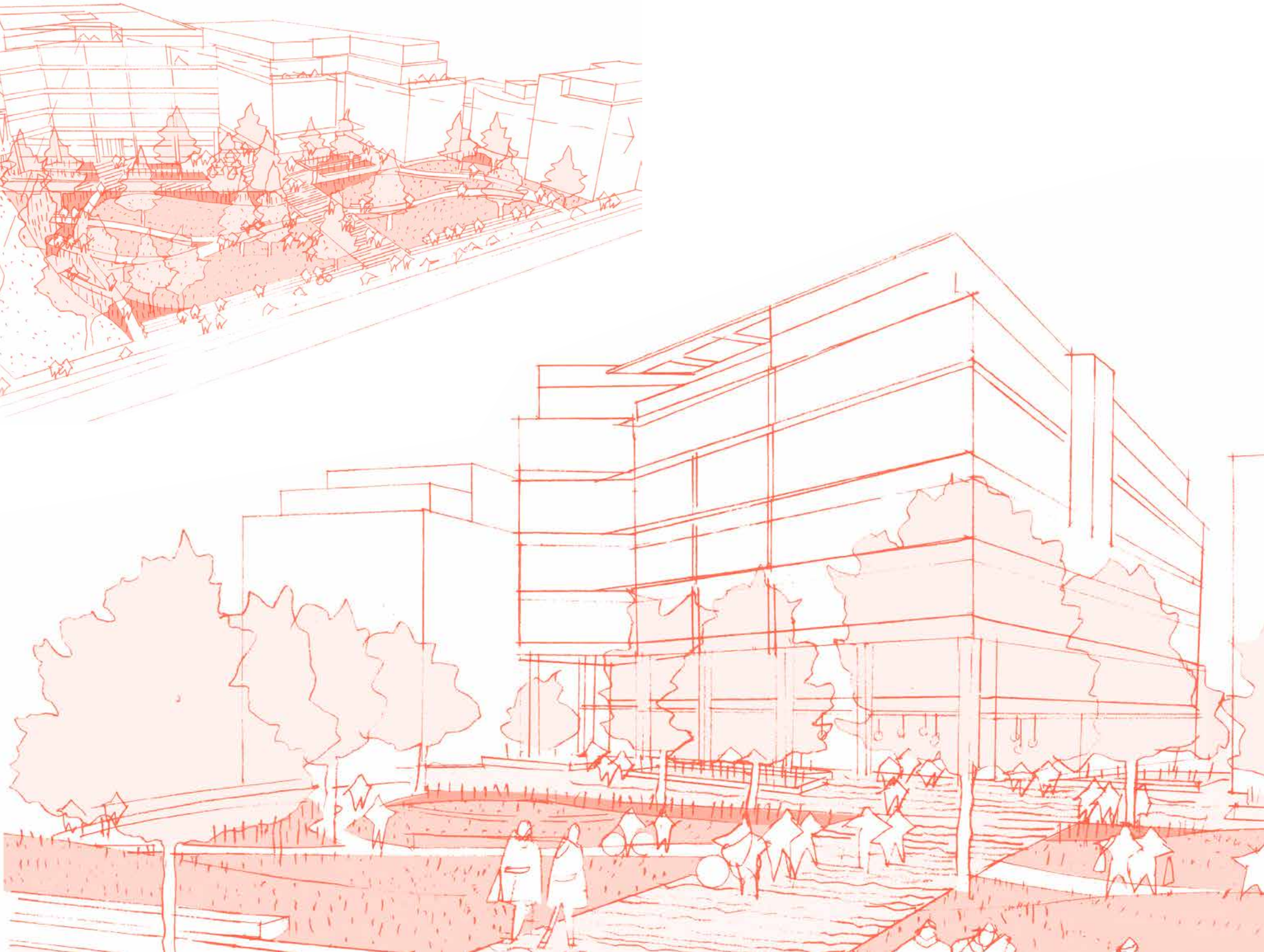

# A LAB LIKE NO OTHER



The new Refinery building at ARC West London, opening in 2024, redefines lab life in London. This creative hub by the river uses landscaped gardens to create engaging communal areas, while inside discover small intimate areas for when you need peace and quiet to test hypotheses and wide open spaces for group buzz and focus. Different days demand different ways of working and Refinery delivers.



**LIFESTYLE**

**A BESPOKE SCIENTIFIC CAMPUS WITH THE FINEST  
CUPS OF COFFEE JUST A BEAN'S THROW AWAY.**



# THAMES LIFE

The Thames is the heart of London, and from ARC West London's supreme vantage point on the banks of the river, it's yours to explore. Take a lunchtime stroll on the tow-path. Watch the rowers on the river or even join the club yourself. Jump on your bike and head downriver for a two-wheeled adventure. Along the way, you'll discover historic sights and some of the capital's best-loved pubs, from The Dove's small and intimate vibes to the famous Blue Anchor.







# EATING & DINING

Hungry for something different? Hammersmith is packed with tempting global cuisine, from vibrant street food to famous restaurants such as The River Café and Sam's Riverside. Within 500m of Refinery you'll find more than 17 dining options, and that's even before you consider the delicious variety of food on offer inside ARC West London itself.





# NIGHT LIFE



While your experiments are running, it's time to explore. Hammersmith is one of London's most dynamic neighbourhoods, with welcoming bars, global cuisine and diverse retail right on our doorstep. If you're in need of a culture fix there are world-class options nearby, including the Lyric Theatre and the Eventim Apollo.

# WORK WELL AT REFINERY

Healthy body, healthy mind. Waterfront at ARC West London promises a great work life balance with cycle use to get to and from work actively encouraged through cycle lockers, showers and even an in-house bike mechanic to keep your wheels turning. For less strenuous exercise, join one of the regular yoga classes.





# A 21ST CENTURY SCIENCE & INNOVATION COMMUNITY

Our campus is curated inside and out, creating vibrant communities with rich event programmes helping you to attract and retain the best talent.

Our Community and Events team is standing by ready to help you get the most out of everything on offer at Refinery – whether it's hooking up with like-minded businesses, or getting your teeth into street food. It's a packed schedule every week in our event spaces.

At Refinery you and your team will have access to the ARC Club; a members lounge providing an extension of your working environment with break-out spaces, a cafe, bookable meeting rooms and event spaces.

Check our app to see what's going on, and you'll discover how Lab Life will work for you.

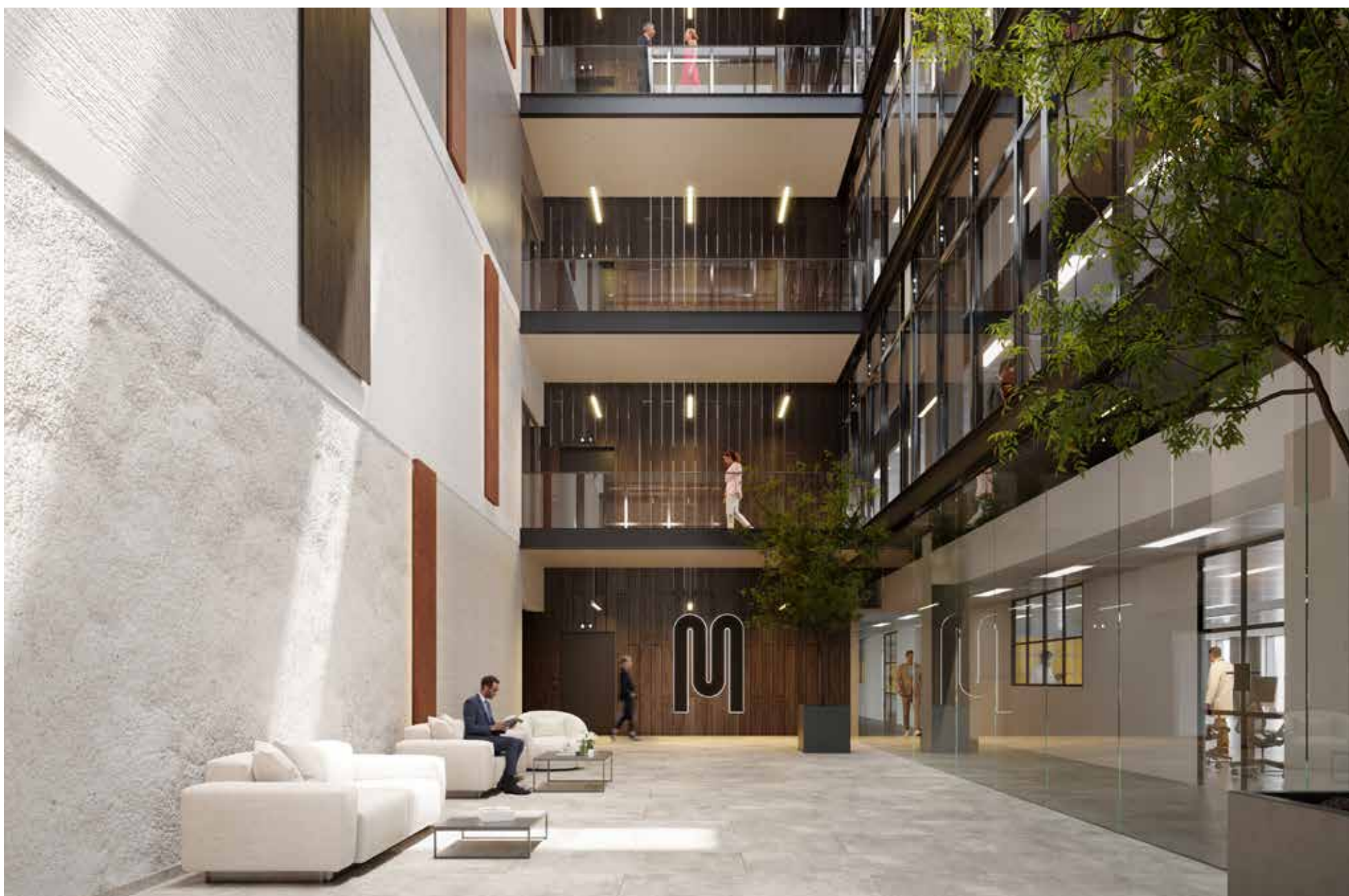



**CONNECTIVITY**

**EASY ACCESS TO THE  
UNDERGROUND AND HEATHROW**

# GREATER LOCATION

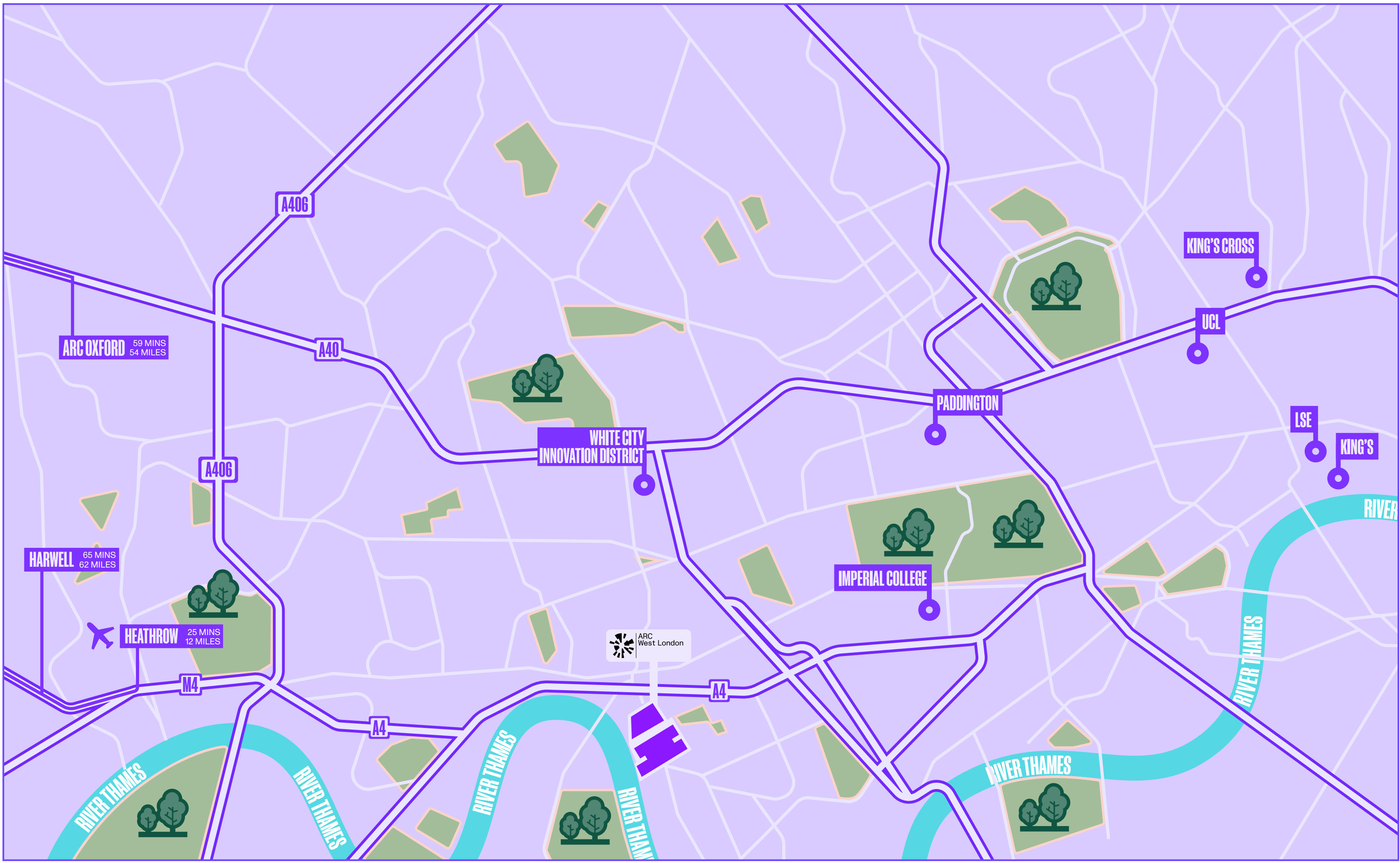

The Refinery is situated in the London corner of the Golden Triangle. When traveling via car, the M4 is reachable within just three miles, with ARC Oxford 55 minutes and Harwell 65 minutes away. Additionally, Heathrow is a handy 17-minute drive.

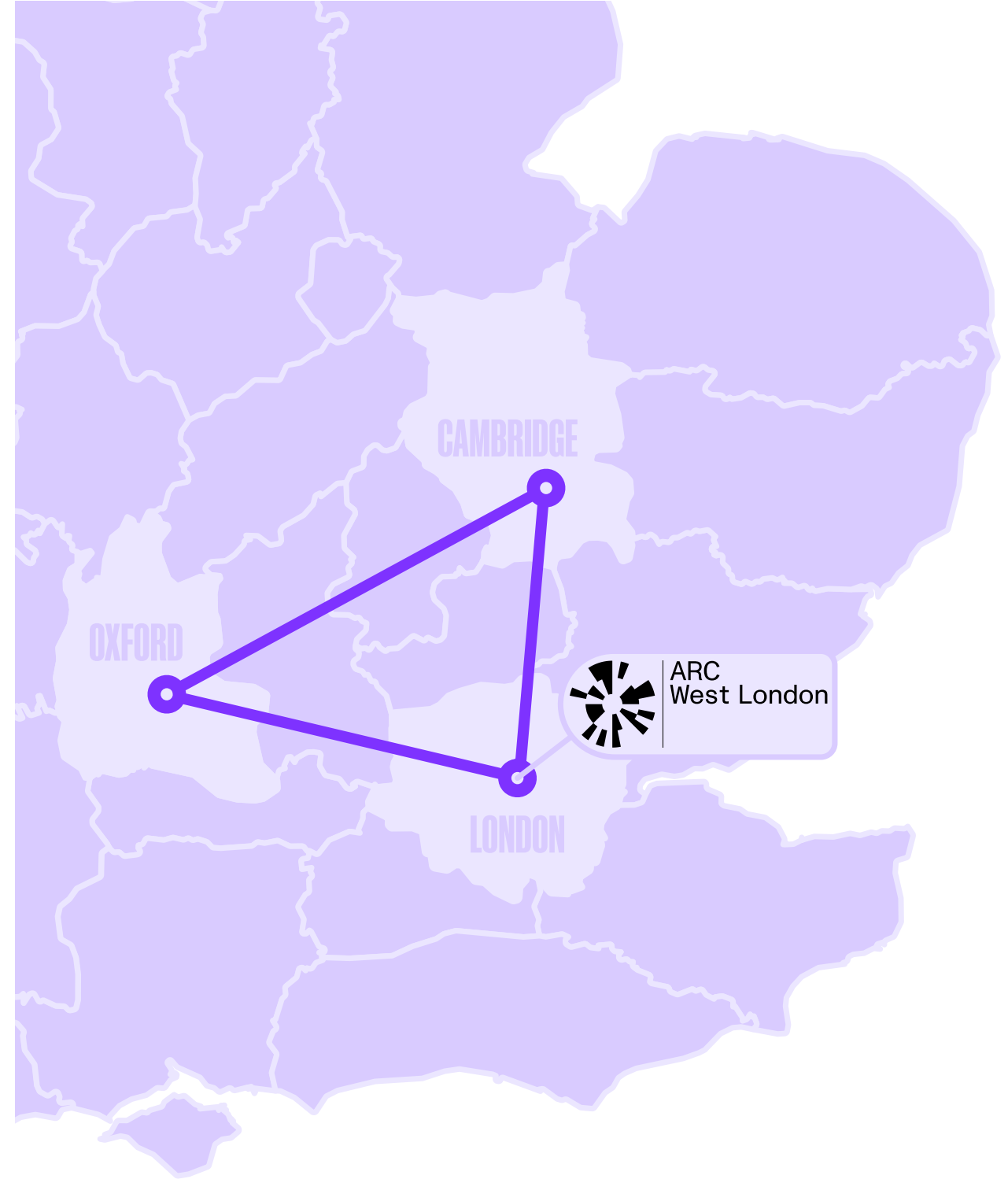

# LOCATION

Nestled on the bank of the Thames, Refinery is just a seven-minute walk from the heart of Hammersmith, one of the capital's major transport hubs. Four tube lines provide fast and regular services across London, delivering you to the West End in just 15 minutes, the Elizabeth line can also be accessed at Paddington in just 13 minutes. Numerous bus routes and bike lanes serve the area.

- |                    |                           |                               |                            |
|--------------------|---------------------------|-------------------------------|----------------------------|
| 01 Eventim Apollo  | 10 Fulham Reach Boat Club | 19 Pure                       | 01 Fulham Reach Boat Club  |
| 02 Lyric Theatre   | 11 Pret a Manger          | 20 Wasabi                     | 02 FRAME Hammersmith       |
| 03 Eat17           | 12 Café Nero              | 21 Sam's Riverside Restaurant | 03 Fitness & Squash Centre |
| 04 Brasserie Blanc | 13 Little Waitrose        | 22 Honest Burger              | 04 Reach Fit               |
| 05 Tesco Express   | 14 Boots Pharmacy         | 23 Riverside Bar & Kitchen    | 05 Better Gym              |
| 06 The Blue Anchor | 15 Riverside Studios      | 24 Sam's Larder               | 06 Virgin Active           |
| 07 The Blue Boat   | 16 Café Plum              |                               | 07 Pure Gym                |
| 08 The River Cafe  | 17 Truth                  |                               | 08 Boom Cycle              |
| 09 The Distillers  | 18 Antipode               |                               |                            |

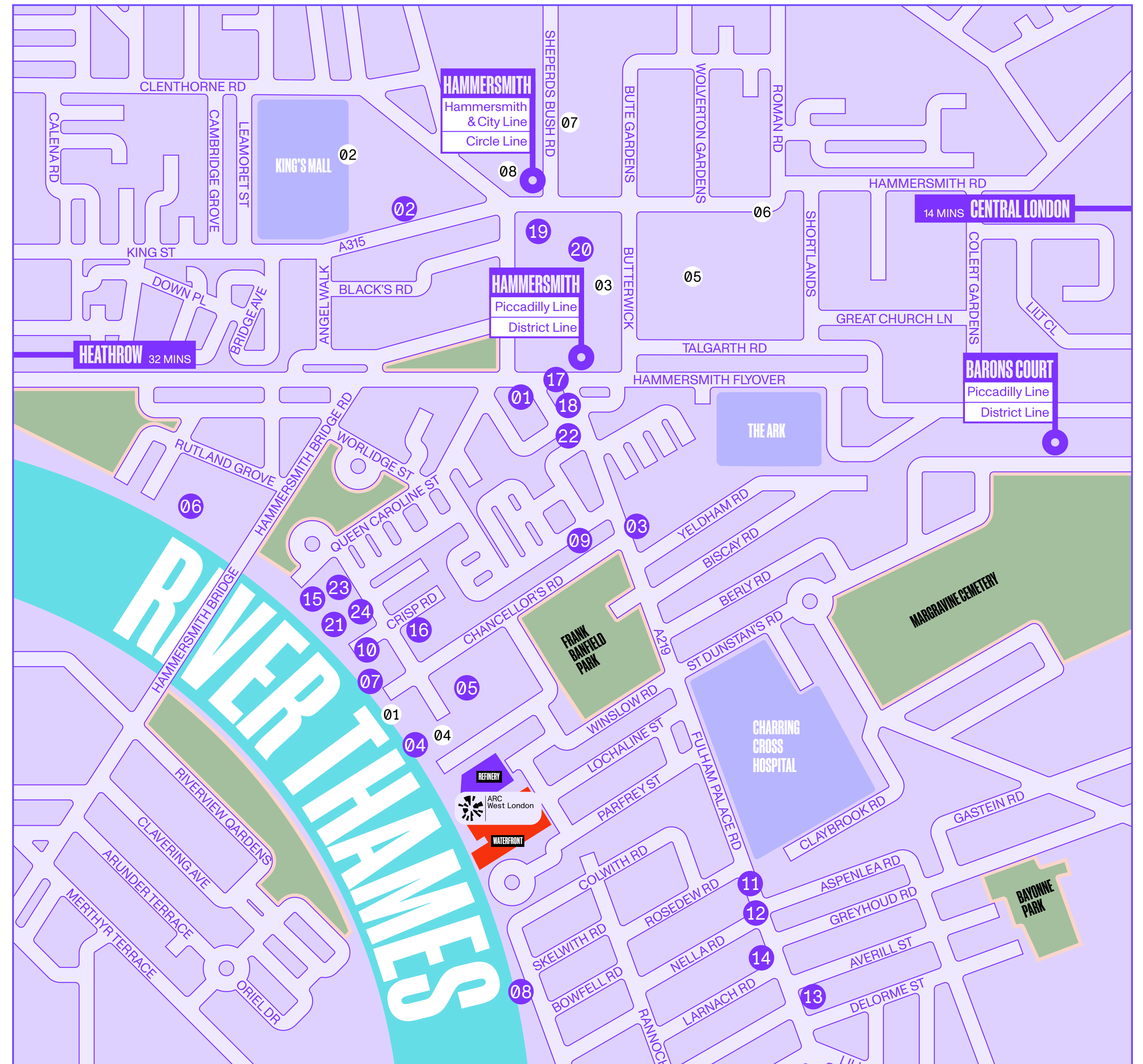

# GETTING AROUND

Hammersmith is one of the most accessible locations by public transport in London. It has 4 tube lines offering direct access to 47% of London's Tube stations and 7 of its 13 rail terminals. By car it is easily accessed from the A4, the main arterial route from West London linking London to Heathrow, the M25 and motorway network.



to the West-End from Hammersmith Station using the Piccadilly line



to Heathrow Terminals 1, 2 & 3 from Hammersmith using the Piccadilly line

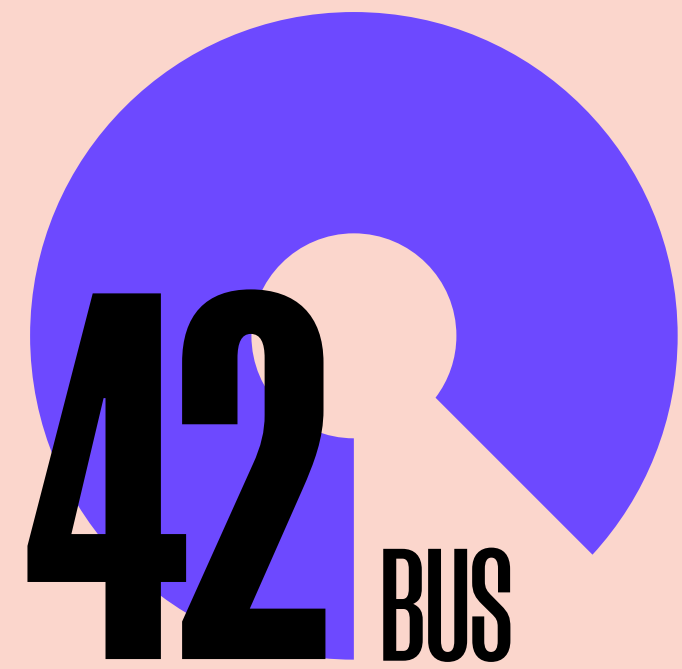

routes serve North, South, East and West London destinations from Hammersmith

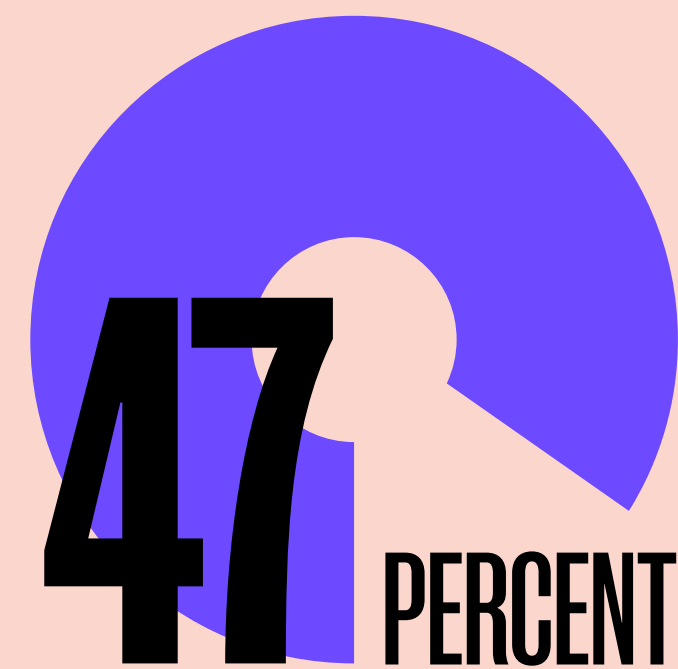

of tube stations can be reached directly from Hammersmith

## To Rail Terminals

- VICTORIA  
10 mins
- PADDINGTON  
13 mins
- WATERLOO  
21 mins
- CANNON ST.  
28 mins
- LIVERPOOL ST.  
30 mins
- EUSTON  
30 mins
- KINGS CROSS  
31 mins

## By Road

- A4  
4 mins
- A40  
10 mins
- M4 (J1)  
15 mins
- M25 (J15)  
17 mins
- HEATHROW AIRPORT  
25 mins
- M40 (J1)  
30 mins
- M1 (J1)  
50 mins

## By Tube

- WHITE CITY (WOOD LANE)  
Hammersmith & City Line - 4 mins
- KNIGHTSBRIDGE  
Piccadilly Line - 11 mins
- GREEN PARK  
Piccadilly Line - 16 mins
- KINGS CROSS  
Piccadilly Line - 31 mins
- HEATHROW AIRPORT  
Piccadilly Line - 32 mins
- BANK (MONUMENT)  
District Line - 36 mins
- LONDON CITY AIRPORT  
District Line & DLR - 53 mins





**TAKE A CLOSER LOOK**



**REFINERY IS FULLY EQUIPPED FOR EVERYTHING  
WORK REQUIRES AND LIFE HAS TO OFFER**

# PLANS & AREAS

LAB / OFFICE SPACE	SQ. FT	SQ. M
5th Floor	14,521	1,349
4th Floor	26,727	2,483
3rd Floor	26,705	2,481
2nd Floor	26,705	2,481
1st Floor	26,673	2,478
Gnd Floor	28,438	2,642
<b>TOTAL GIA</b>	<b>149,769</b>	<b>13,914</b>

AMENITY SPACE	SQ. FT	SQ. M
A – 5th Floor Club Room	1,076	100
B – Reception & Business Lounge	5,538	514
C – Event Studio & Presentation Suite	1,171	109
D – Motherlabs	12,574	1,168
E – Cafe Scientifique	3,924	365
<b>TOTAL</b>	<b>24,283</b>	<b>2,256</b>

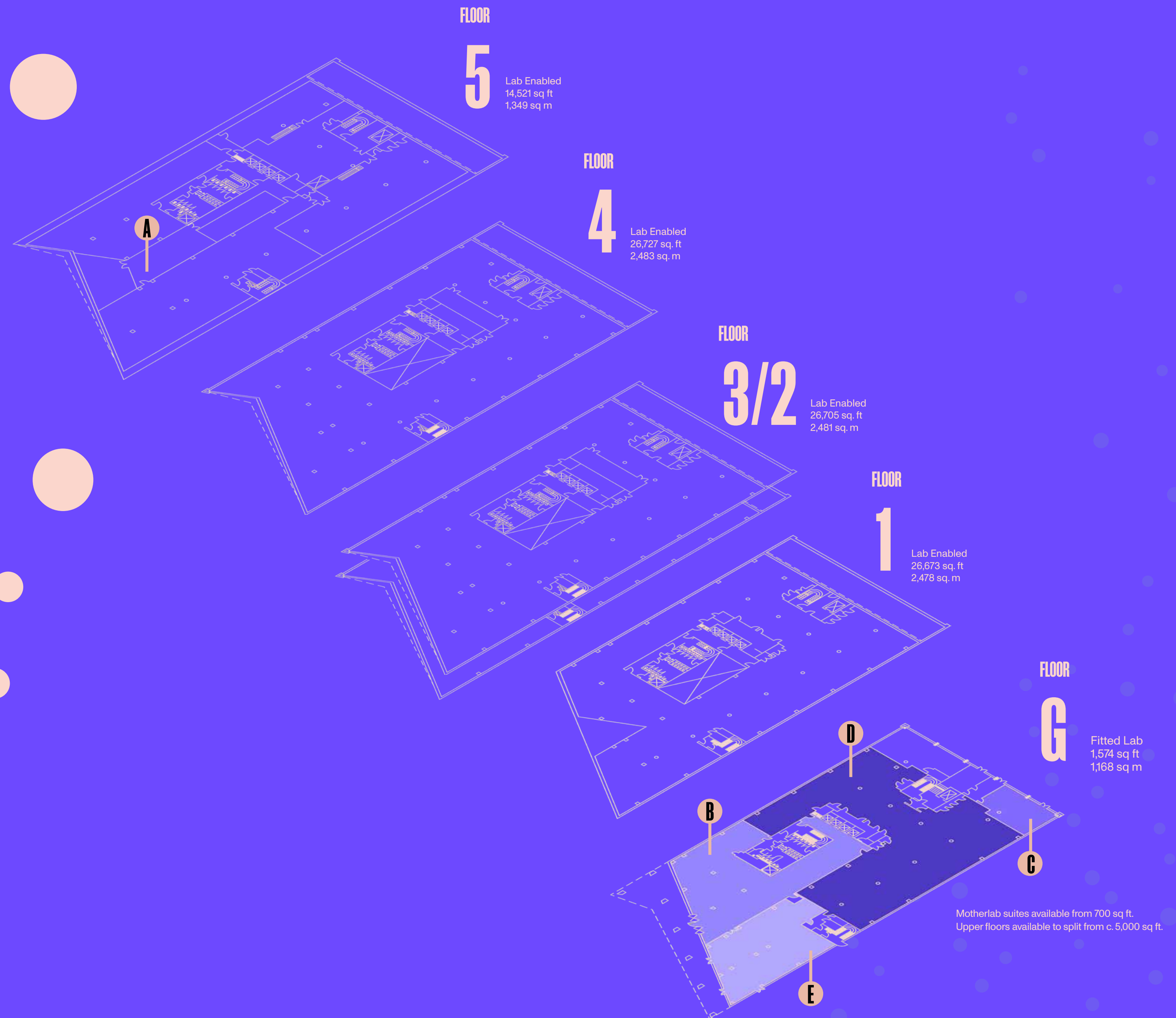

FLOOR

# G

Fitted Lab  
28,438 sq ft  
2,642 sq m

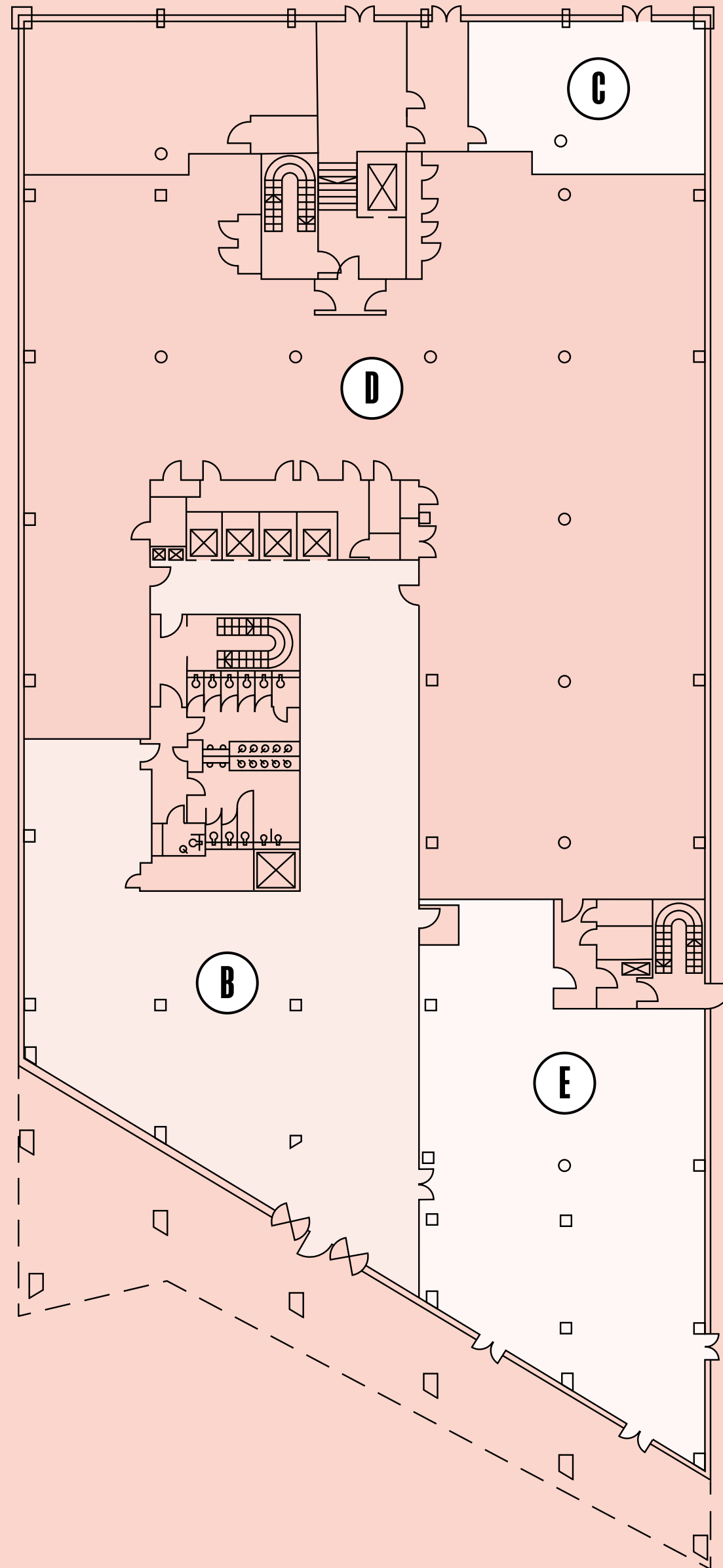

FLOOR

# 1

Lab Enabled  
26,673 sq ft  
2,642 sq. m

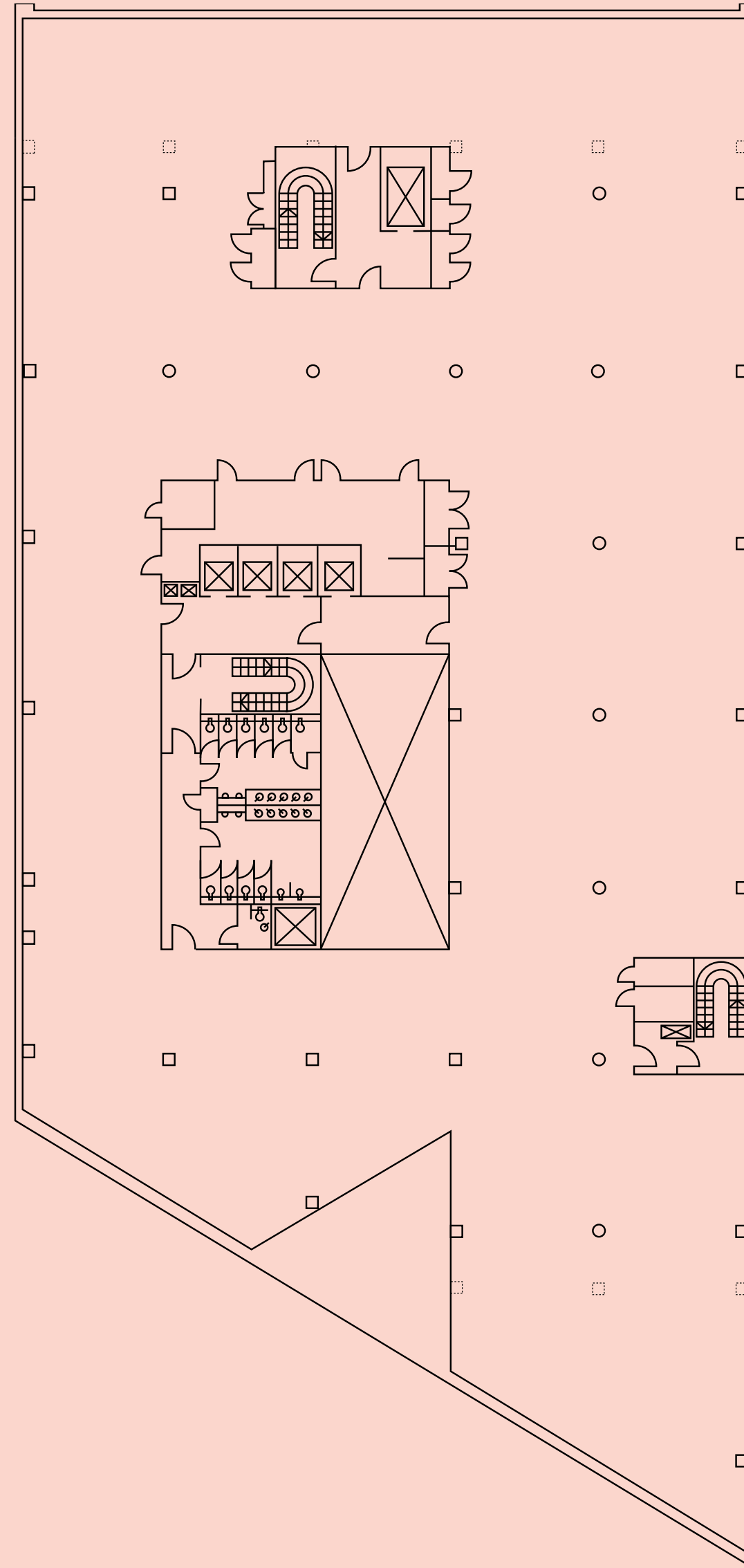

FLOOR

# 2

Lab Enabled  
26,705 sq ft  
2,481 sq. m

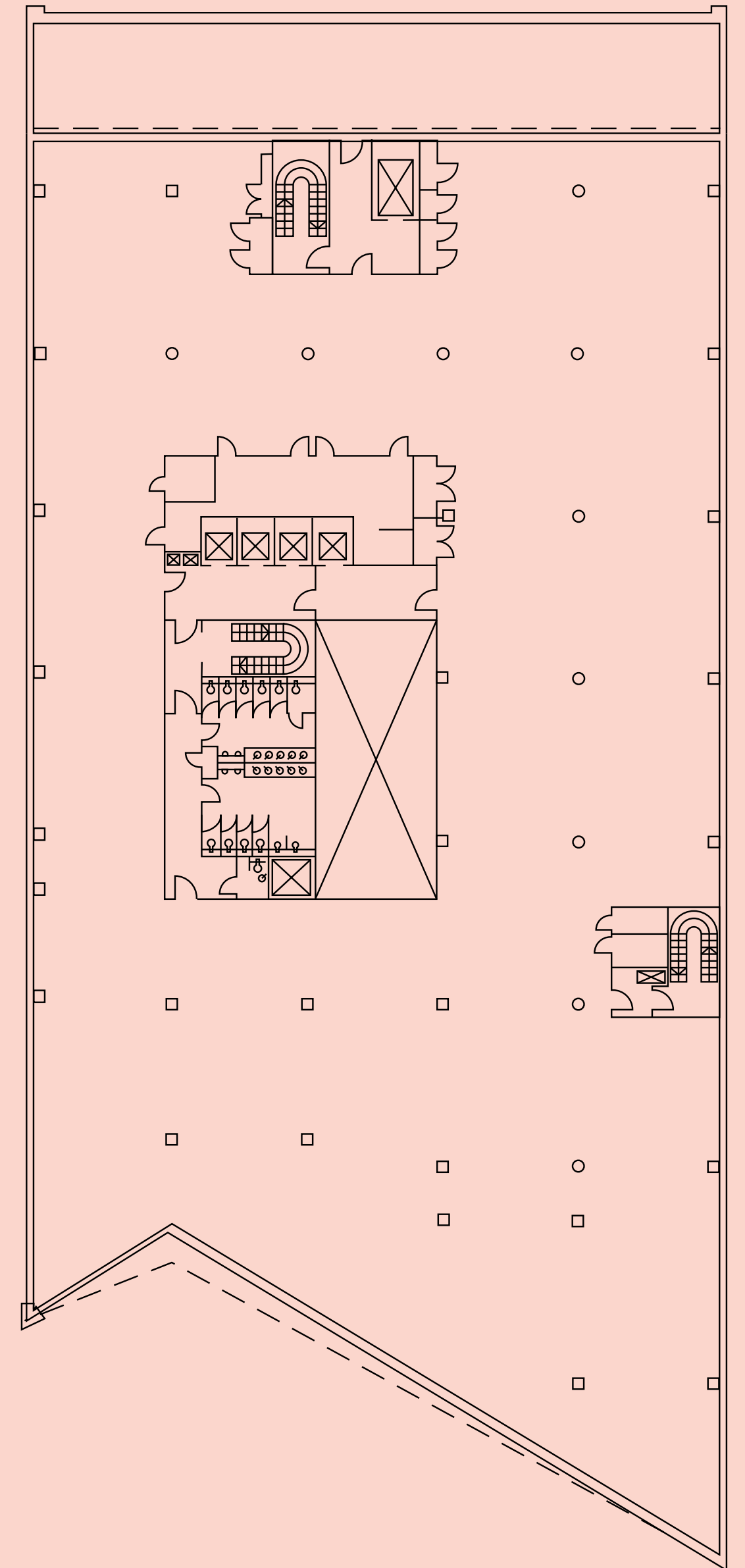

FLOOR

# 3

Lab Enabled  
26,705 sq ft  
2,481 sq. m

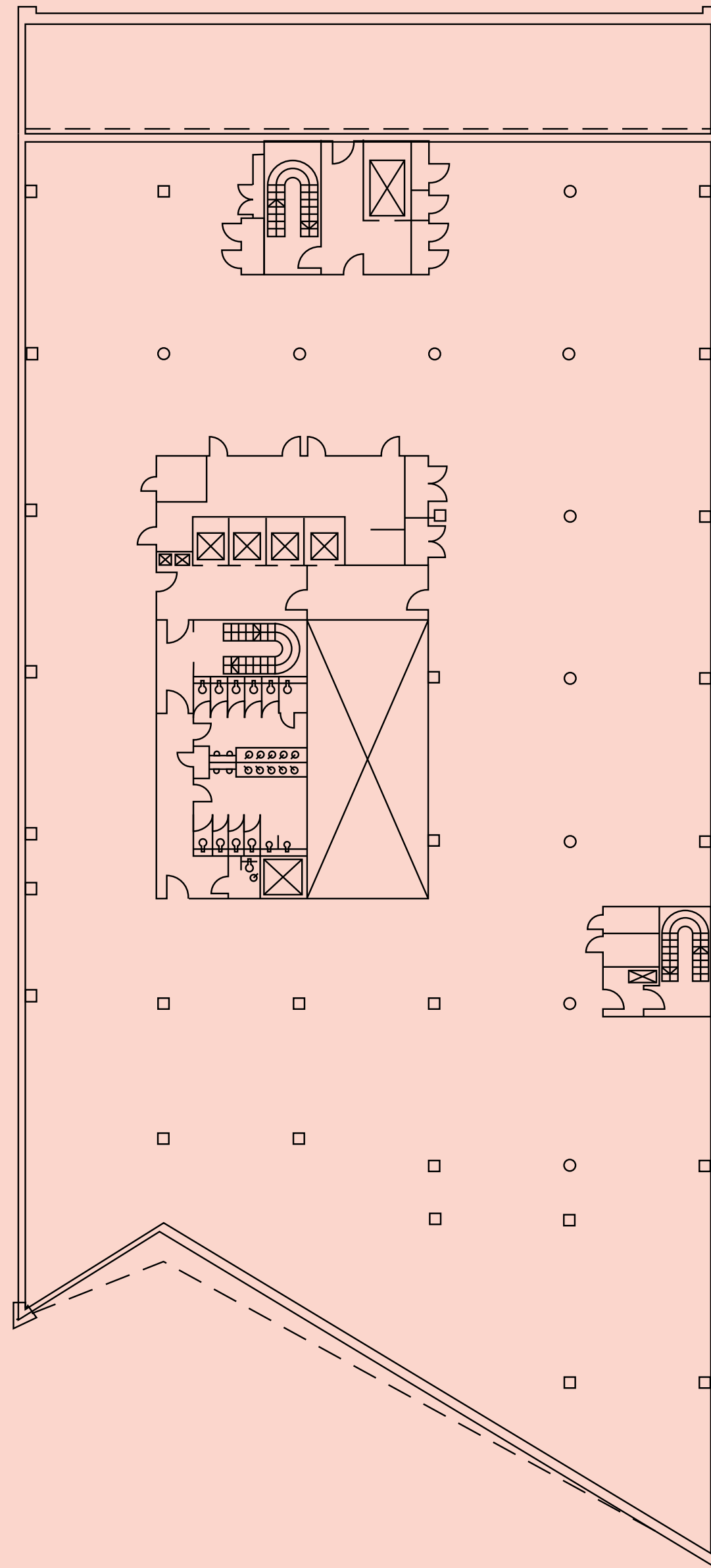

FLOOR

# 4

Lab Enabled  
26,727 sq ft  
2,483 sq. m

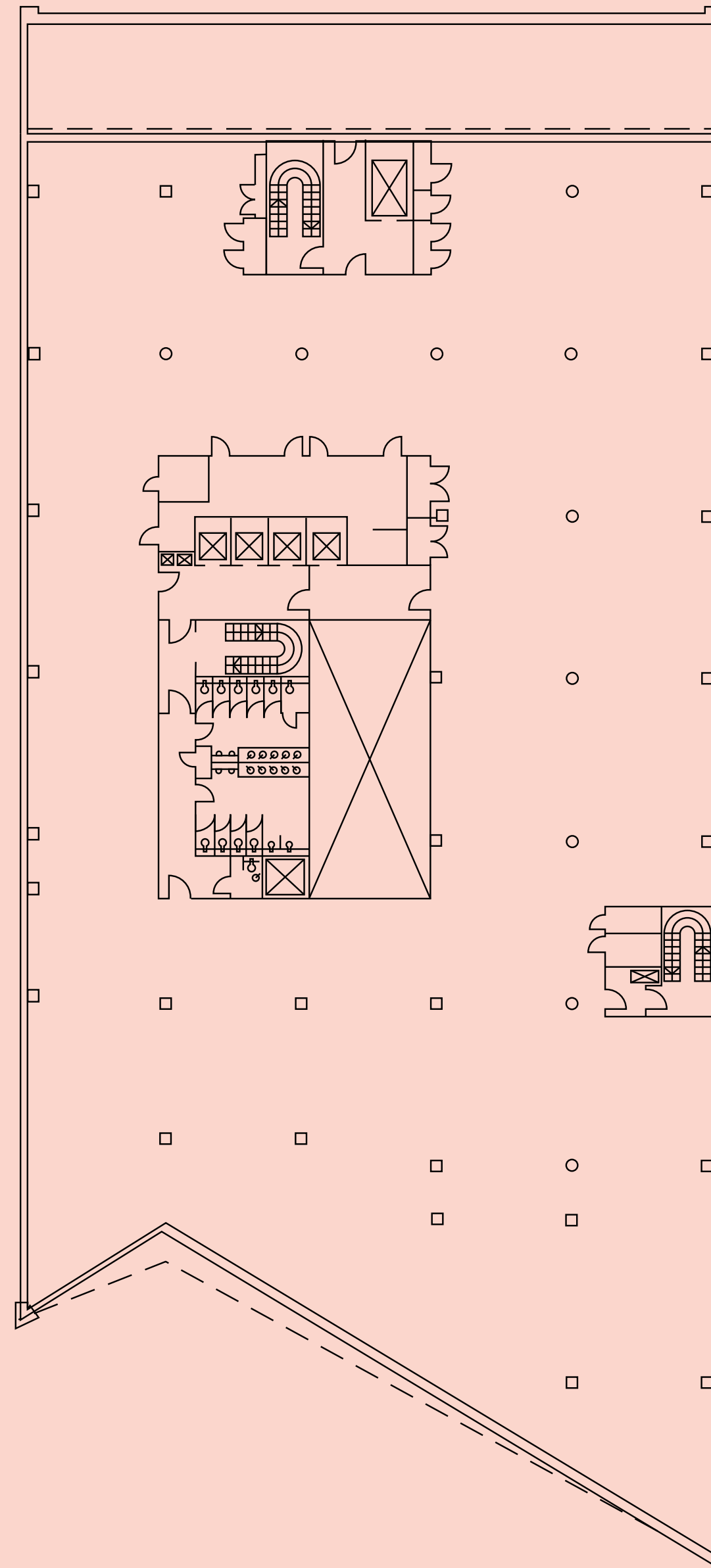

FLOOR

# 5

Lab / Office Space  
14,521 sq. ft  
1,349 sq. m

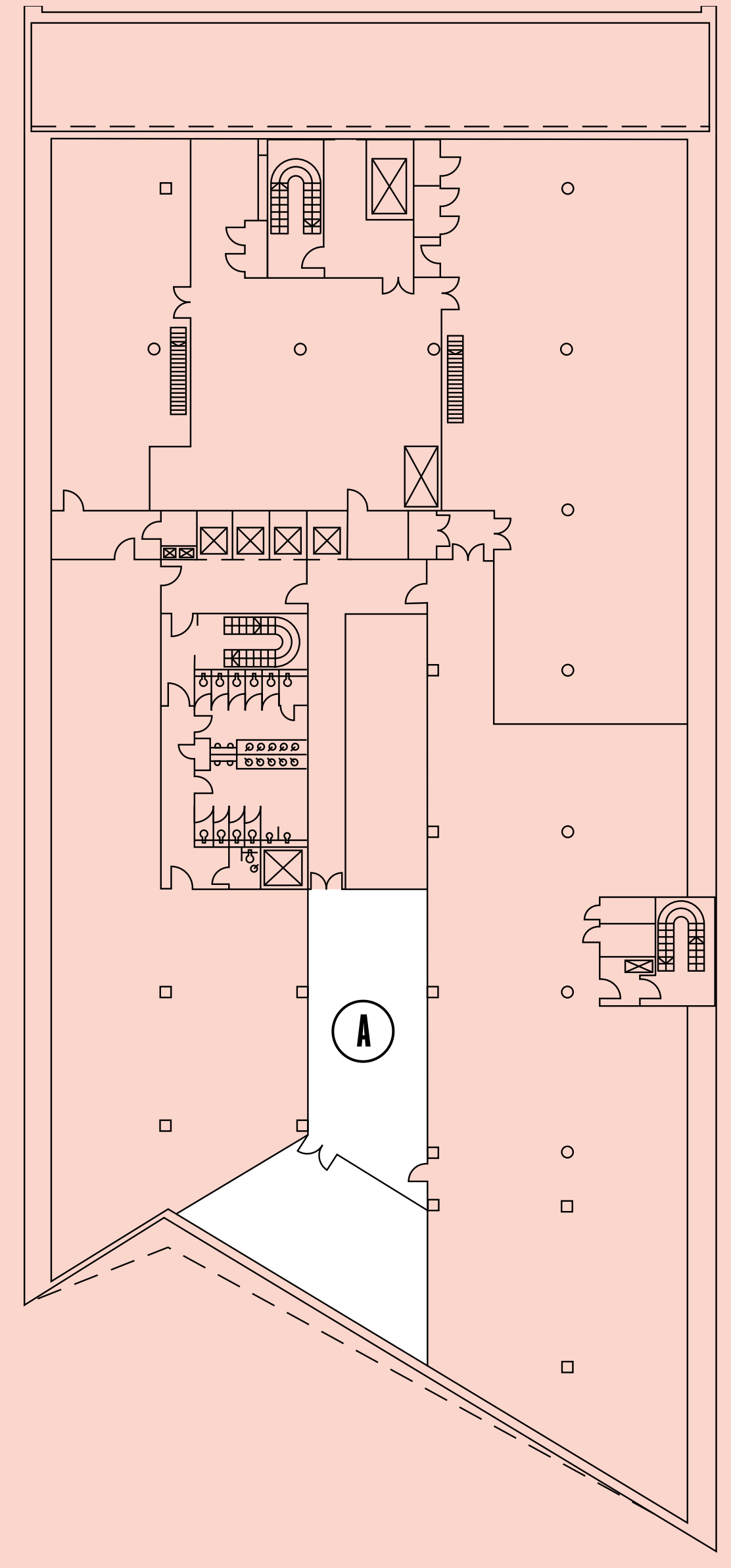

# SPECIFICATION

## AMENITIES

- 19 car parking spaces with EV charging points
- 24hr Concierge
- 4,000 sq ft Café / Restaurant
- 5,500 sq ft Business Lounge and Atrium with coffee bar and superfast Wifi
- 1,200 sq ft Event Studio and Presentation Suite
- Rooftop Clubroom
- Dedicated ARC West London APP

## PERFORMANCE

- Means of Escape: 1:6m<sup>2</sup>
- Occupational Density 1:8m<sup>2</sup>
- Planning grid of 1.5 metres
- 4m floor to floor height throughout
- Floor to Ceiling Height 2.7m
- Finished floor level to Soffit:
  - Ground to 2nd Floor: 3.425m
  - 3rd to 5th Floor: 3.625m
- Floor loading: up to 4.85kN/ sq m (3.85+1.0)
- Fully accessed raised floors
- 4 × 13-person passenger lifts

## COMFORT

- Four Pipe Fan Coil Air Conditioning System
- Designed for 1:8 sq m occupation
- Fresh air at a rate of 12 litres/sec/person
- 10 air changes/hour extract to toilet areas

## SMART BUILDING TECHNOLOGY

- BMS capable of smart sensor integration to monitor air quality and space utilisation
- Contactless access control

## THE BIKE GARAGE

- Secure, ride-in garage for 182 bikes (12 short stay visitor spaces externally)
- 14 executive showers
- 182 Storage lockers
- Drying Rooms
- Fully equipped maintenance bench
- 2 Workstands
- Compressor



ARC  
West London





# LAB READY

Refinery has always been home to pioneers. As a lab-enabled building, designed from the basement up to accommodate Containment Level 2 laboratories. Life Science occupiers will appreciate Hammersmith's ideal location, within a 30 minute radius of Imperial College's White City campus, Charing Cross Hospital, The Francis Crick Institute and University College London cluster at King's Cross, as well as Guy's and St Thomas Hospitals NHS Trust at Waterloo.

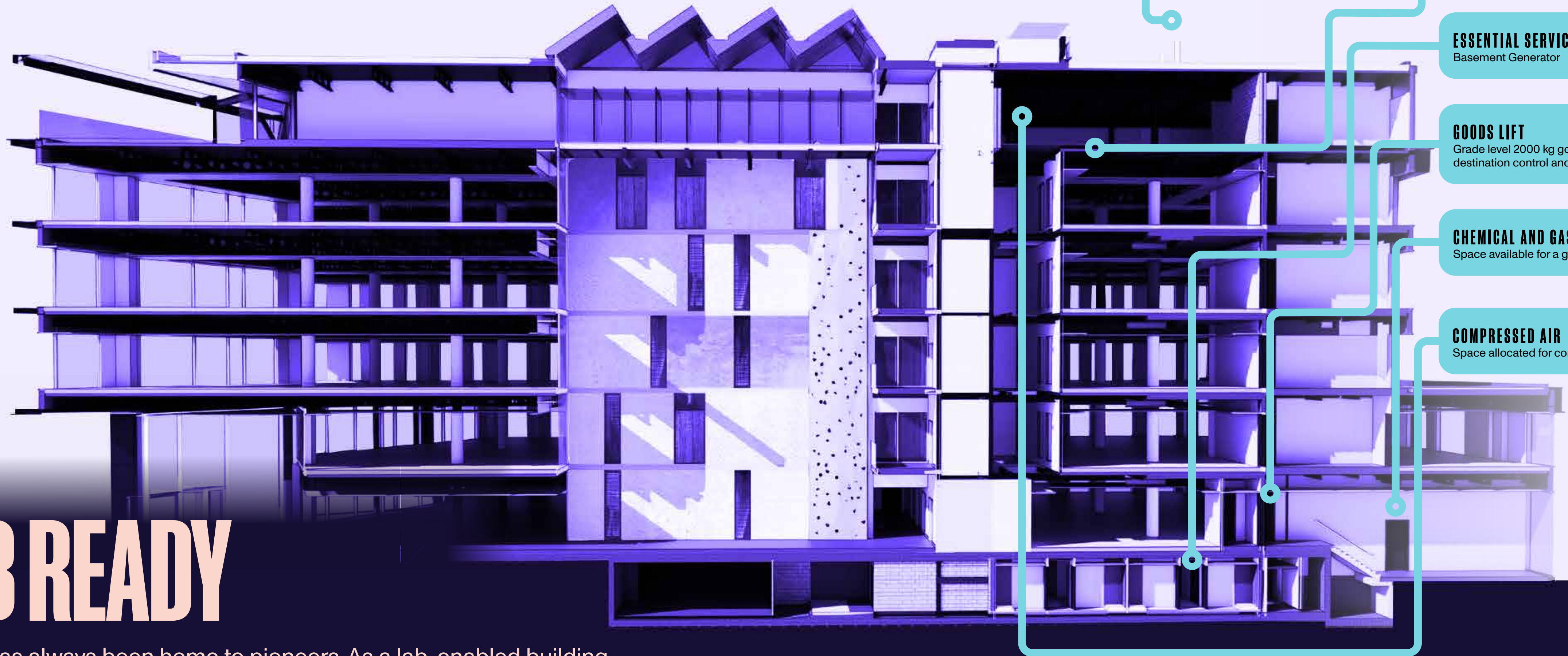

**FUME EXTRACT**  
Dedicated risers for fume extract with steel work ready to receive flues, connecting to roof top enclosure providing 3m clearance

**ADDITIONAL CAPACITY**  
Dedicated plant and riser space for supplemental cooling plant

**ESSENTIAL SERVICES CONTINUITY**  
Basement Generator

**GOODS LIFT**  
Grade level 2000 kg goods lift with destination control and gas detection

**CHEMICAL AND GAS STORAGE**  
Space available for a ground floor store

**COMPRESSED AIR**  
Space allocated for compressed air plant

**FLOOR & CEILING**  
Choice of floor and ceiling systems for efficient services distribution

**MECHANICAL & ELECTRICAL**  
Pre-perforated cladding for easy installation of supplemental Air Handling Units to accommodate 6+ air changes / hr for all or part of each floor. Incoming supply of 2.5 mVA

**WATER TREATMENT**  
Connection points on each floor

**DRAINAGE**  
Vulcathene throughout connecting to clay



# Motherlabs



ARC West London is home to Motherlabs - flexible, fully-managed lab space.

Motherlabs provides the critical infrastructure to help organisations grow sustainably, to smartly innovate and to move ideas seamlessly from concept, to lab, to commercialisation at pace. Motherlabs is already at ARC West London with additional CL2 facilities planned for the Refinery.

The shared facilities at Motherlabs don't just support your business, but can help remove workload from your staff from sterilising equipment to managing clinical waste.

Key specification includes:

- Private lab with dedicated write-up / office space
- Established lab protocols
- 6 ach/hr
- Vulcathene drainage
- Vinyl lab flooring
- Perimeter dado trunking
- Specialist piped gases
- On-site lab manager
- Shared facility including Autoclave, Dishwasher, Ice Machine, Ducted Fume Hood, and CL2 facilities

# SUSTAINABILITY



Sustainability is at the forefront of all ARC developments and Refinery has been designed & developed to meet the highest standards.

## KEY VALUES INCLUDE:

- Targeting BREEAM Very Good
- Targeting EPC A
- 3,950 sq. m of gardens and green space Bio-diverse green roofs with beehives to aid pollination
- Secure, ride-in garage for 182 bikes
- Daylight sensing LED light fittings to office floors
- Insulation to achieve standard of Zero Ozone Depletion Potential
- Up to 30% recycled content in the glass used for the production of glazed units
- BMS energy monitoring will highlight any source of excessive energy consumption within the building
- PV array at roof level circa 200 sq m
- Building services heating system is not reliant fossil fuels being all electric
- Rainwater harvesting for use externally
- Up to 93% recycled content used in steel fabrication
- Between 40-75% recycled content within aluminum curtain walling components and up to 59% in façade materials
- High efficiency chiller plant for chilled water, with heat recovery to LTH
- Reduction or diversion of waste from landfill
- All timber will be FSC
- London Urban Green Factor LUGF score of 0.21



**ARC LIFE**



**A SCIENCE CAMPUS WHERE YOU  
CAN DISCOVER MORE**

# COLLABORATION AND CREATIVITY

When you join the ARC West London community you also become part of the ARC network of leading science and innovation campuses with exclusive membership benefits including access to collaboration space in every ARC site.

The ARC network is country-wide and means every member is part of something bigger with broader, faster, knowledge sharing facilitated by dedicated cluster and community managers. ARC's energising environments and wellbeing initiatives create spaces where talent can thrive.



The Rosalind Franklin Institute

Oxford NANOPORE Technologies

vaccitech

# ARC HARWELL

600,000 sq. ft over 700 acres  
3 million sq. ft of future development

ANIMAL DYNAMICS

Perspectum

Oxford Biomedica

# ARC OXFORD

610,000 sq. ft over 88 acres  
600,000 sq. ft of future development

AMGEN

Bristol Myers Squibb

parexel

# ARC UXBRIDGE

350,000 sq ft over 70 acres

EpsilonGen

GENinCode

SANIA THERAPEUTICS

# ARC WEST LONDON

272,000 sq. ft over 3.5 acres  
inc. 150,000 sq. ft Refinery building coming 2024

# CONTACT

## LETTING AGENTS

### **TOM MELLOWS**

M: +44 (0) 787 055 5955

E: tmellows@savills.com

### **STUART CHAMBERS**

M: +44 (0) 787 099 9339

E: stuart.chambers@savills.com

### **RUPERT DANDO**

M: +44 (0) 781 362 4276

E: rupert.dando@savills.com

savills.co.uk



### **PADDY SHIPP**

M +44 (0) 746 915 5531

E: paddy.shipp@eu.jll.com

### **BRIDGET PARTRIDGE**

M: +44 (0) 792 130 9816

E: bridget.partridge@eu.jll.com

### **MATT SYMONS**

M: +44 (0) 792 850 1324

E: matt.symons@eu.jll.com

jll.co.uk



### **ANDREW DAVIES**

T: +44 (0)7545 009 618

E: andrew.davies@arcgroup.io

### **DAN PAGELLA**

T: +44 (0)7831 894 332

E: dan.pagella@arcgroup.io

# ARC.